

Microwaves

Anja Skrivervik

anja.skrivervik@epfl.ch, 021 693 4635

Summary (microwaves)

- Introduction and applications
- A short reminder transmission line theory
- An introduction to waveguides
- Microwave circuit theory
- Microwave components
- Microwave filters
- An introduction to microwave measurements

Course form

- ex cathedra
- supervised and unsupervised exercises
- handouts and corrections on the web (Moodle)
- Two tests (13th of November and 11th of December)

History

- 1872 Publication of "a treatise on electricity and magnetism" by James Clerk Maxwell
- 1887 Publication of Oliver Heaviside's comments on Maxwell's work
- 1887 Lord Rayleigh proves theoretically the concept of waveguides
- 1891 Experimental verification of Maxwell's theory by Heinrich Herz
- 1901 First transatlantic wireless link by Guglielmo Marconi
- 1903 Regular wireless telegraphic service
- 1918 First tubes and continuous wave generators
- 1920 First use of frequency shifters in detectors, mixers, and receivers
- 1921 First transatlantic link in medium waves
- 1938 First Portable phone (Motorola)

History

- 1936 Simultaneous rediscovery of the waveguide concept by G.C. Southworth and W.L. Barrow
- 1938-1945 : intensive research on RADAR
- 1948 Distributed filter theory by Richards
- 1950 First cavity filters
- 1950 Introduction of planar microwave transmission lines (first stripline, then microstrip)
- 1950 Apparition of TWT amplifiers
- 1960 Apparition of the first microwave transistors
- 1970 First MMICs
- 1971 First CAD tools

Maxwell's equations
(Telecom style)

$$\nabla \times \mathbf{H} = \mathbf{J} + \varepsilon \frac{\partial \mathbf{E}}{\partial t}$$

$$\nabla \times \mathbf{E} = -\mu \frac{\partial \mathbf{H}}{\partial t}$$

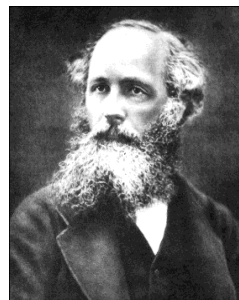

Electric currents Varying in space and time

acting in a specific medium create

electromagnetic waves

Maxwell - Heaviside

$$\left. \begin{aligned} \frac{dQ}{dz} - \frac{dR}{dy} &= \mu \frac{d\alpha}{dt} \\ \frac{dP}{dy} - \frac{dQ}{dx} &= \mu \frac{d\gamma}{dt} \\ \frac{dR}{dx} - \frac{dP}{dz} &= \mu \frac{d\beta}{dt} \end{aligned} \right\} \nabla \times \mathbf{E} = -\frac{\partial \mathbf{B}}{\partial t}$$

$$\left. \begin{aligned} p &= \frac{1}{4\pi} \left(\frac{d\gamma}{dy} - \frac{d\beta}{dz} - \frac{1}{\epsilon^2} \frac{dP}{dt} \right) \\ q &= \frac{1}{4\pi} \left(\frac{d\alpha}{dz} - \frac{d\gamma}{dx} - \frac{1}{\epsilon^2} \frac{dQ}{dt} \right) \\ r &= \frac{1}{4\pi} \left(\frac{d\beta}{dx} - \frac{d\alpha}{dy} - \frac{1}{\epsilon^2} \frac{dR}{dt} \right) \end{aligned} \right\} \nabla \times \mathbf{H} = \frac{\partial \mathbf{D}}{\partial t} + \mathbf{J}$$

From Maxwell (1865) to Hertz (1888)

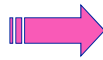

H. Hertz

Heinrich Hertz (1857–1894).
(Photograph courtesy of Deutsches
Museum, Munich.)

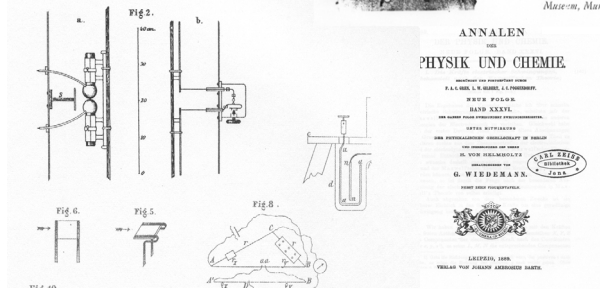

Herzian dipole

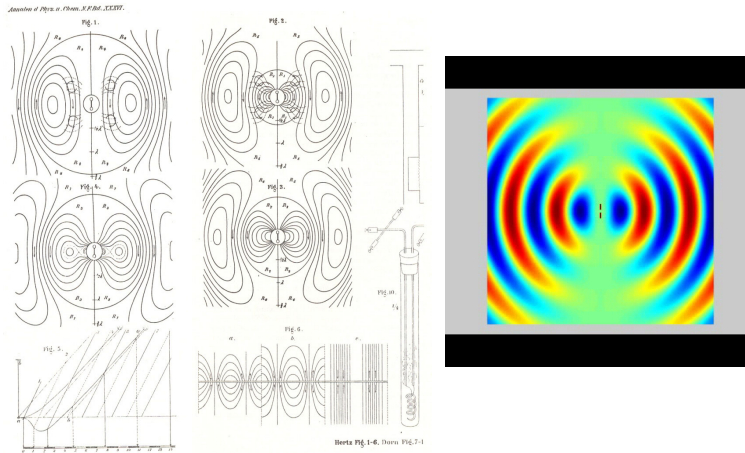

History

- 1872 Publication of "a treatise on electricity and magnetism" by James Clerk Maxwell
- 1887 Publication of Oliver Heaviside's comments on Maxwell's work
- 1887 Lord Rayleigh proves theoretically the concept of waveguides
- 1891 Experimental verification of Maxwell's theory by Heinrich Herz
- 1901 First transatlantic wireless link by Guglielmo Marconi
- 1903 Regular wireless telegraphic service
- 1918 First tubes and continuous wave generators
- 1920 First use of frequency shifters in detectors, mixers, and receivers
- 1921 First transatlantic link in medium waves
- 1938 First Portable phone (Motorola)

Marconi : A pioneer's work

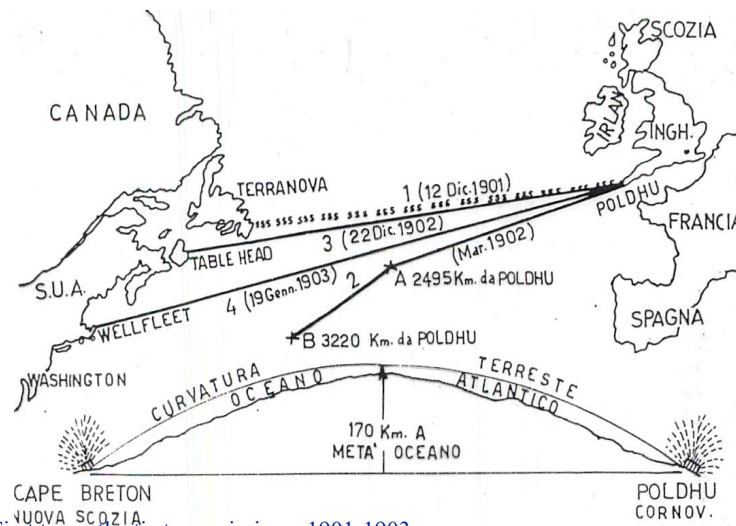

First transatlantic transmissions: 1901-1903

- 1- Poldhu St. John 12 December 1901 3400 km
- 2- Poldhu - Philadelphia (ship) March 1902 discovery of night effect
- 3- Activation of the link Glace Bay Poldhu 22 December 1902
- 4- **Activation of the link** Cape Cod Poldhu 19 January 1903

Marconi :

Despite the opposition which I had received from many quarters, often that of most eminent men, it was still my opinion that electric waves would not be stopped by the curvature of the earth, and therefore could be made to travel any distance, separating any two places on our planet. From the very first of my experiments, I was sincerely convinced of this (Jacot and Collier, 1935: 64).

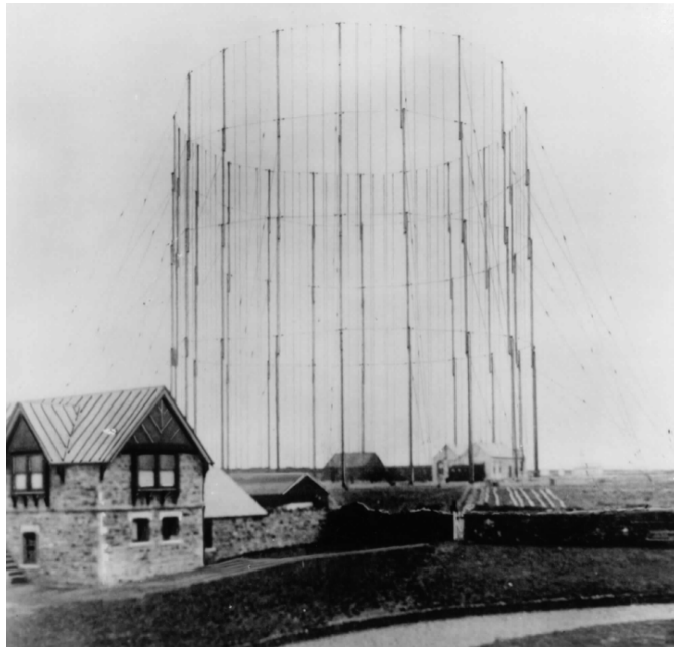

Photograph of the original conical antenna system installed at Poldhu, Cornwall (after **BAE Systems Marconi Research Centre, Chelmsford, Essex**)

EPFL Une antenne de Guglielmo Marconi (1901)

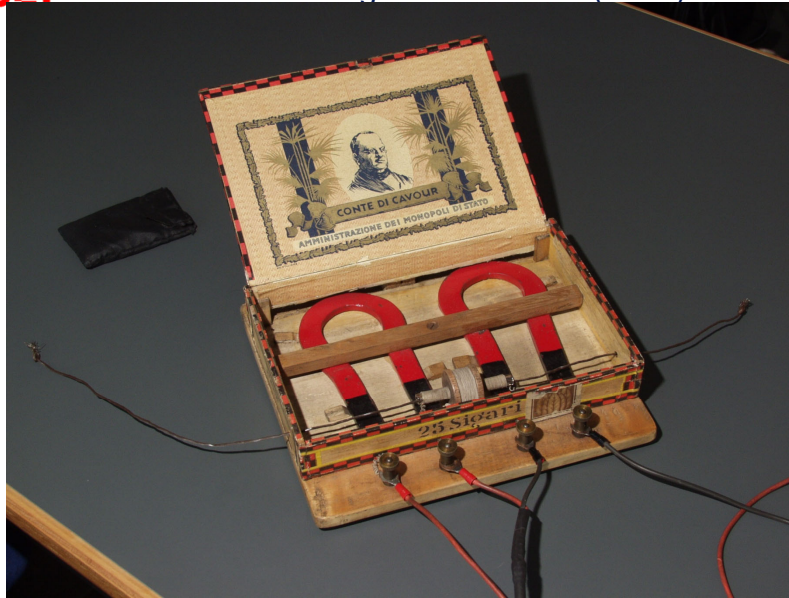

MAG-EPFL 15

EPFL

History

- 1872 Publication of "a treatise on electricity and magnetism" by James Clerk Maxwell
- 1887 Publication of Oliver Heaviside's comments on Maxwell's work
- 1887 Lord Rayleigh proves theoretically the concept of waveguides
- 1891 Experimental verification of Maxwell's theory by Heinrich Herz
- 1901 First transatlantic wireless link by Guglielmo Marconi
- 1903 Regular wireless telegraphic service
- 1918 First tubes and continuous wave generators
- 1920 First use of frequency shifters in detectors, mixers, and receivers
- 1921 First transatlantic link in medium waves
- 1938 First Portable phone (Motorola)

MAG-EPFL 16

Microwave tubes

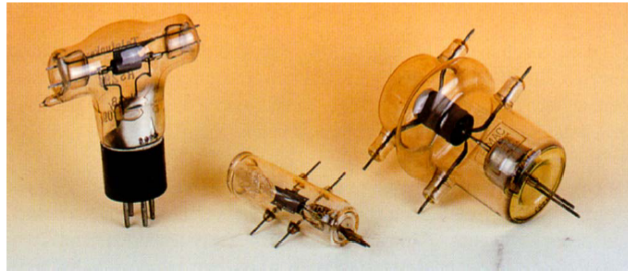
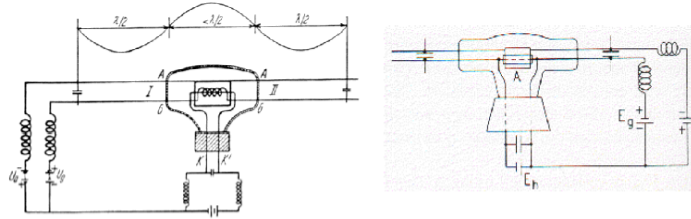

Retarding-field tube RS296 and its circuit (Kühle 1932 at Telefunken)
 "Hammer Tube" [8,11]. The photograph also shows the retarding field tubes 8012 of RCA (middle) and VT 127 A of Eimac (right)

History

- 1936 Simultaneous rediscovery of the waveguide concept by G.C. Southworth and W.L. Barrow
- 1938-1945 : intensive research on RADAR
- 1948 Distributed filter theory by Richards
- 1950 First cavity filters
- 1950 Introduction of planar microwave transmission lines (first stripline, then microstrip)
- 1950 Apparition of TWT amplifiers
- 1960 Apparition of the first microwave transistors
- 1970 First MMICs
- 1971 First CAD tools

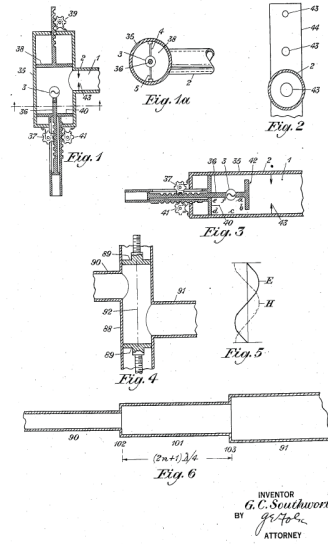

1st page of patent
by Southworth

History

- 1936 Simultaneous rediscovery of the waveguide concept by G.C. Southworth and W.L. Barrow
- 1938-1945 : intensive research on RADAR
- 1948 Distributed filter theory by Richards
- 1950 First cavity filters
- 1950 Introduction of planar microwave transmission lines (first stripline, then microstrip)
- 1950 Apparition of TWT amplifiers
- 1960 Apparition of the first microwave transistor, 1963: Gunn diode
- 1970 First MMICs
- 1971 First CAD tools

EPFL

example of distributed filter:
LPF realized in microstrip technology



MAG-EPFL 21

EPFL

cavity filter
(exploded)

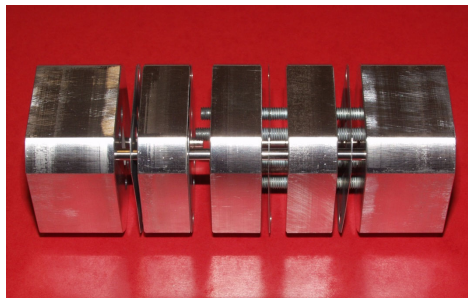

irises

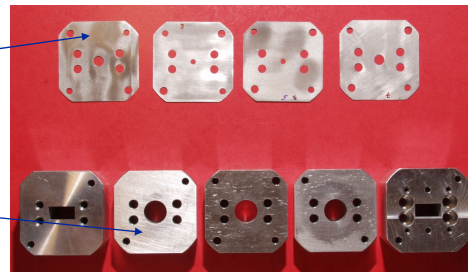

waveguide sections

MAG-EPFL 22

example of microstrip circuit: complete
2.45 GHz transceiver

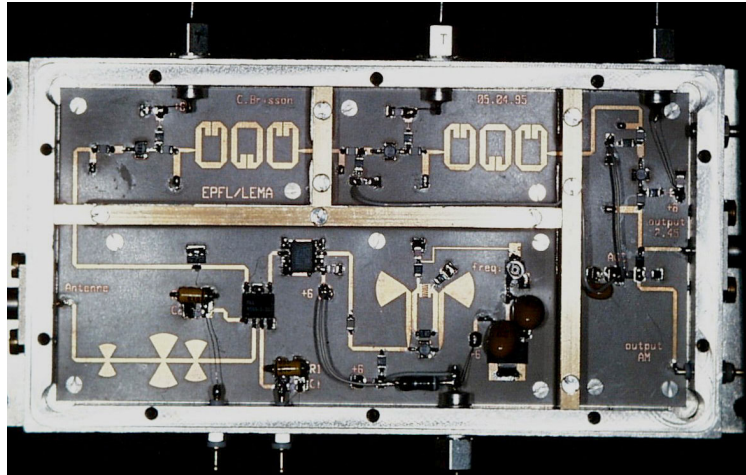

MAG-EPFL 23

Definition of microwaves

Frequency (f)	300 MHz-300 GHz
Period (T)	3 ns - 3 ps
Wavelength (λ)	1 m - 1 mm
Energy (hf)	$1.2 \cdot 10^{-6} \text{eV} - 1.2 \cdot 10^{-3} \text{eV}$

MAG-EPFL 24

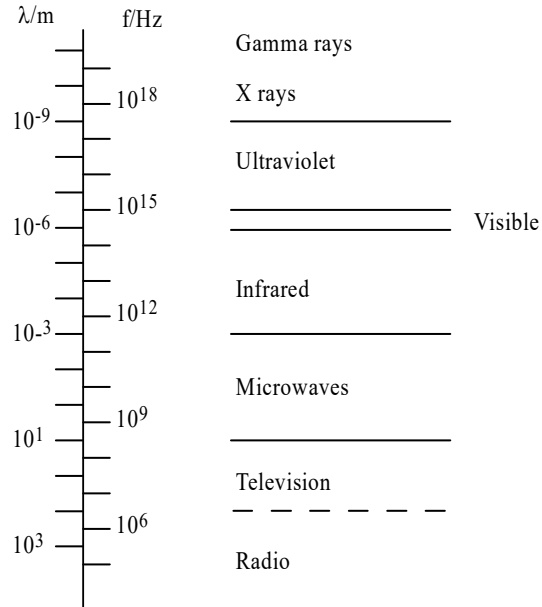

Band	Frequenc y
L	1-2 GHz
S	2-4 GHz
C	4-8 GHz
X	8-12 GHz
Ku	12-18 GHz
K	18-26 GHz
Ka	26-40 GHz
Q	40-60 GHz
E	60-90 GHz

Properties of microwaves

- Bandwidth
 - 1% of 10 GHz = 100 MHz, but 1% of 100 MHz = 1MHz
- Transparency of the Ionosphere
 - Satellites

Ionosphere

4 layers: D, E, F1, F2
altitude: circa 70-800 km

$$\epsilon_e = \epsilon_0 \left(1 - \frac{\omega_p^2}{\omega^2} \right) \qquad \omega_p = \sqrt{\frac{Nq^2}{m\epsilon_0}}$$

N : number of ions/volume

q : charge of the electron

m : mass of the electron

$\epsilon_0 = 8.854 \cdot 10^{-12}$ As/Vm : permittivity of free space.

Ionosphere

$\omega \ll \omega_p$

$\epsilon_e \rightarrow -\infty$

$Z = \sqrt{\frac{\mu}{\epsilon}} \rightarrow j0$

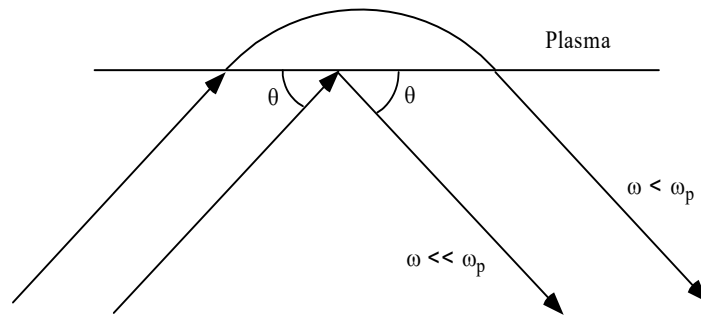

Ionosphere

$\omega = \omega_p$

$\epsilon_e \rightarrow 0$

$k = \omega\sqrt{\epsilon\mu} = 0$

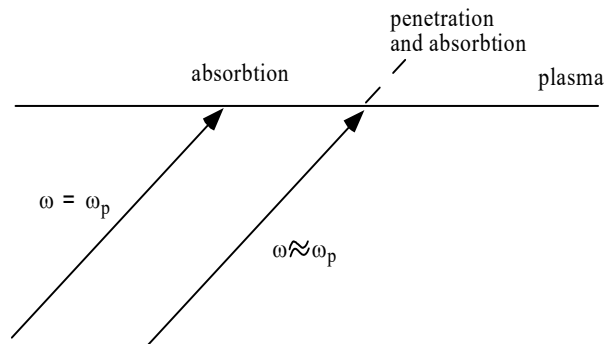

Ionosphere

$$\omega \gg \omega_p$$

$$\epsilon_e \rightarrow 1$$

$$k = \omega \sqrt{\epsilon \mu} = k_o$$

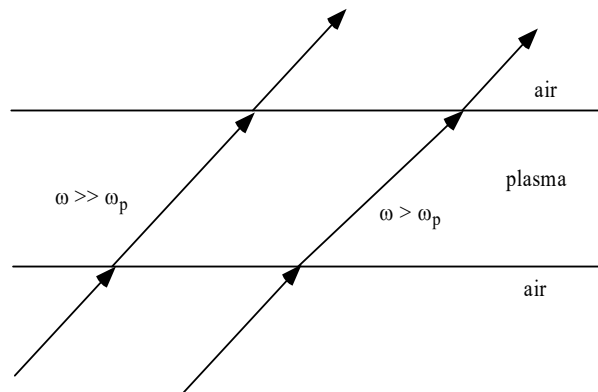

Properties of microwaves

- Transparency of the atmosphere up to 10 GHz
- Electromagnetic noise Minimum between 1 and 10 GHz, + low noise amps

Atmosphere

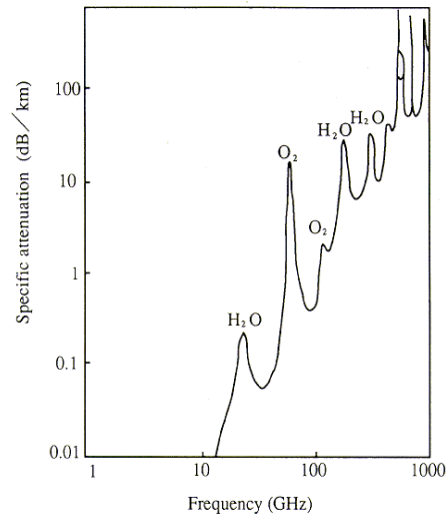

strategic use
of the atmospheric
absorption!

detection of
pollution from
satellites

Fig.3.2.1 Microwave absorption due to atmospheric gases

Atmosphere

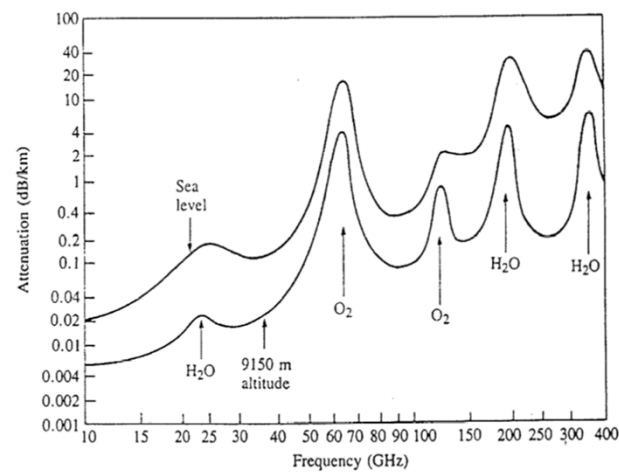

Noise

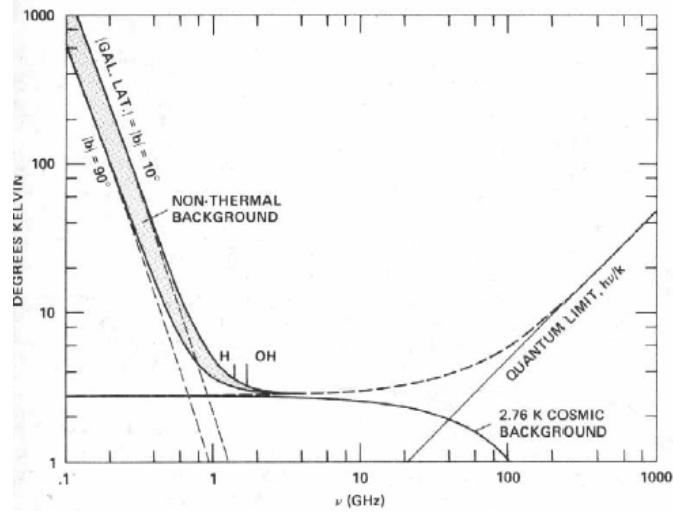

Propagation

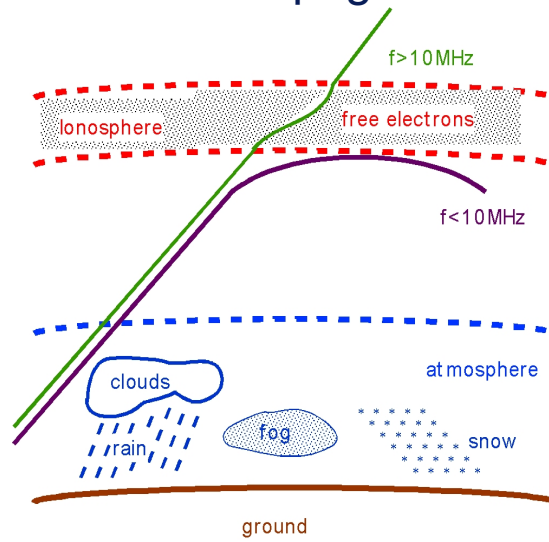

Link with Mars

- Mars Pathfinder Mission : 1996
- Distance Earth-Mars : 228'000'000 km

Friis formula:

$$P_r = P_f \cdot G_1 \cdot G_2 \cdot (\lambda/4\pi L)^2$$

From Earth to Mars

- Frequency : 7.175 GHz ($\lambda = 41.8$ mm)
- Terrestrial Antenna Gain : 4'265'795
 - $\varnothing = 70$ m
- Satellite Antenna Gain : 13.8
- Emitted Power on Earth : 22 kW
 - (a very small car)
- Received power on Mars : $3.16 \cdot 10^{-16}$ W
 - (Not really much)

From Mars to Earth

- Frequency : 8.425 GHz ($\lambda = 35.6$ mm)
- Terrestrial Antenna Gain : 25'118'864
- Satellite Antenna Gain : 141
- Power emitted on Mars : 13 W
 - (a low consumption halogen lamp)
- Received power on earth : $7 \cdot 10^{-18}$ W
 - (nothing !!)

Velocity : 10cm/s
weight : ~ 1g

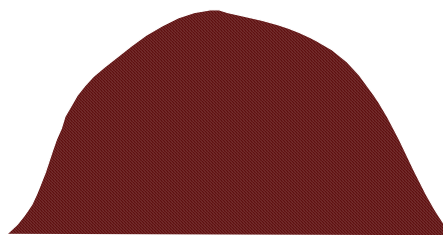
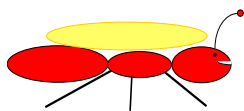

Power that the ant needs to develop : $\sim 10^{-3}$ W

1 million billions time more than the received power on Earth !!!

Properties of microwaves

- Directivity of the antennas
- Reflections on obstacles
 - Effective surfaces, radar
- Interaction with matter
 - Heating, measurement
- Non ionizing radiation
 - causing no mutation
- Stable oscillation frequencies
 - Atomic clocks and frequency references

Definition of microwaves

Frequency (f)	300 MHz-300 GHz
Period (T)	3 ns - 3 ps
Wavelength (λ)	1 m - 1 mm
Energy (hf)	$1.2 \cdot 10^{-6}\text{eV} - 1.2 \cdot 10^{-3}\text{eV}$

Directivity of antennas

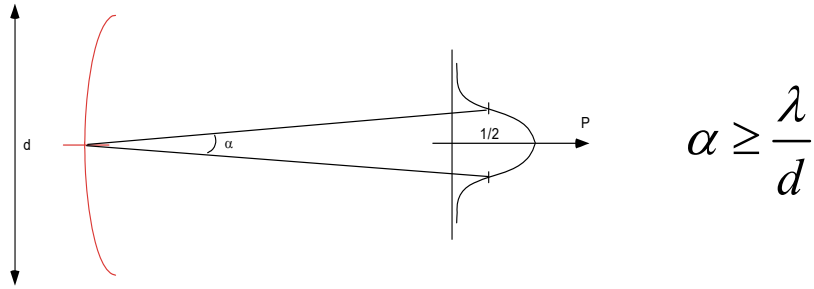

Directivity of antennas

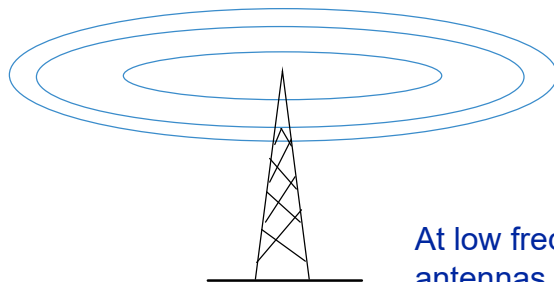

At low frequencies
antennas are omnidirectional

Directivity of antennas

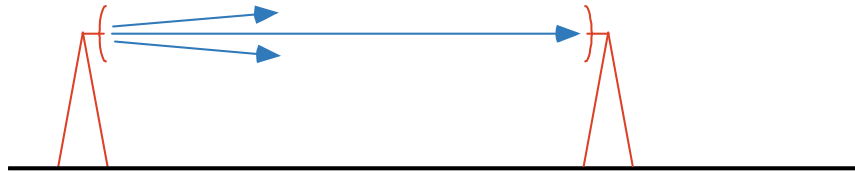

At high frequencies, antennas are directive

Arecibo dish antenna



diameter: 305 m !

EPFL

Arecibo feed

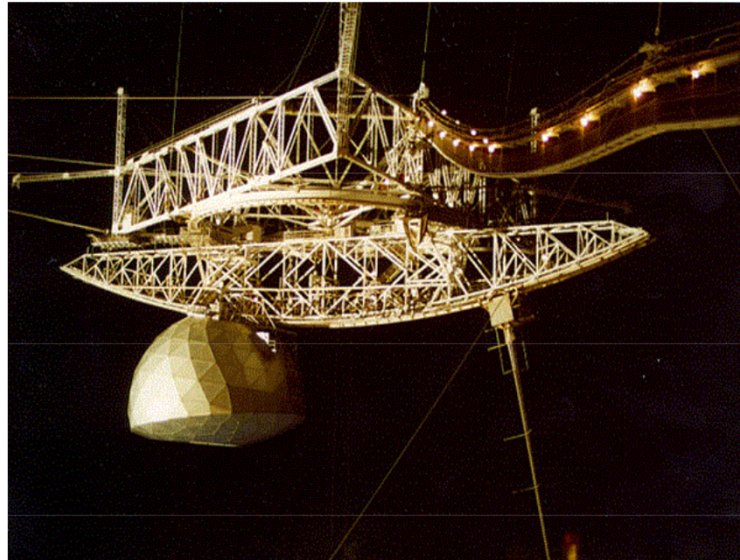

MAG-EPFL 47

EPFL

Google earth view



MAG-EPFL 48

Arecibo beamwidth

- 50 MHz, $\lambda=6\text{m}$ and $\alpha=1.12^\circ$
- 10GHz, $\lambda=3\text{cm}$ and $\alpha=0.0056^\circ$

Properties of microwaves

- Directivity of the antennas
- Reflections on obstacles
 - Effective surfaces, radar
- Interaction with matter
 - Heating, measurement
- Non ionizing radiation
 - causing no mutation
- Stable oscillation frequencies
 - Atomic clocks and frequency references

Definition of microwaves

Frequency (f)	300 MHz-300 GHz
Period (T)	3 ns - 3 ps
Wavelength (λ)	1 m - 1 mm
Energy (hf)	$1.2 \cdot 10^{-6}\text{eV} - 1.2 \cdot 10^{-3}\text{eV}$

Interaction with matter : microwave heating

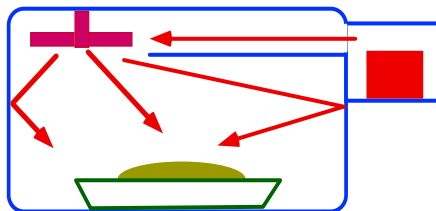

The waves penetrate into the matter and generate heat inside

Interaction with matter : microwave heating

- Applicators :
 - Cavities
 - Progressive Wave
 - Slow wave
 - Antenna
- Principle :
 - The wave is absorbed by the water. The absorption decreases when T increases

Interaction with matter : microwave heating

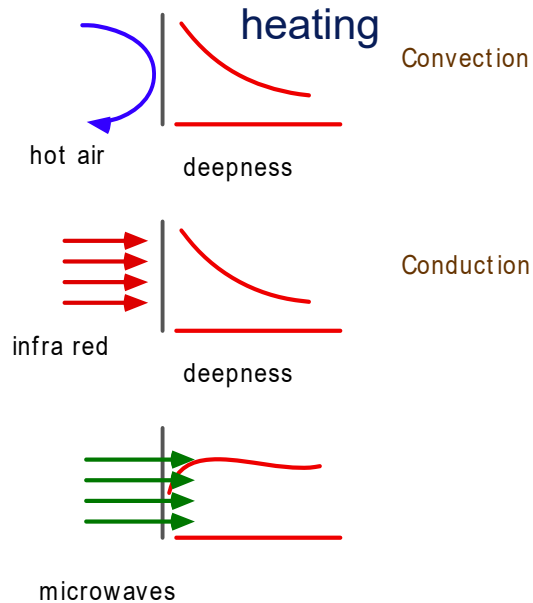

Interaction with matter : microwave heating. Advantages

- Good efficiency (50% of power transfer to the element which is heated)
- Selective heating
 - cereals or insects
 - electrons and ions
- Moderate cost and maintenance
- Less storage room needed as the heating cycle is shorter
- Less losses in the process
- No pre-heating needed

Interaction with matter : microwave heating. Drawbacks

- Costly to develop
- Impossible to grill
- Difficult to evacuate certain solvents needed in the printing industry
- Needs skilled workforce
- High security needed

Properties of microwaves

- Directivity of the antennas
- Reflections on obstacles
 - Effective surfaces, radar
- Interaction with matter
 - Heating, measurement
- Non ionizing radiation
 - causing no mutation
- Stable oscillation frequencies
 - Atomic clocks and frequency references

Definition of microwaves

Frequency (f)	300 MHz-300 GHz
Period (T)	3 ns - 3 ps
Wavelength (λ)	1 m - 1 mm
Energy (hf)	$1.2 \cdot 10^{-6} \text{eV} - 1.2 \cdot 10^{-3} \text{eV}$

Biological effects : ionization

molecular cohesion energy

Type	<i>kJ/mole</i>	<i>eV/atom</i>
ionic	750	7800
dipolar	~20	207
Van der Waals	10	103
covalent		2,5

In microwaves, the energy of a photon is :

 $1,2 \cdot 10^{-6}$ to $1,2 \cdot 10^{-3}$ eV

Biological effects : Thermal effects

- Limits exist since many years
 - USA : ~ 10 mW/cm² = 100 W/m²
 - Russia : ~ 10 μ W/cm² = 0.1 W/m²
- Diathermy : 1-10 kW/m² !!
- Solar flux : 1 kW/m² (at ground level)

Are electromagnetic waves dangerous?

(1)
 Energy at a
MICROSCOPIC level
 $E = hf$
 (Planck's constant
 times frequency)

	Frequency	wavelength	protection factor
Radio FM	100 MHz	3 m	800'000
Natel	1 GHz	30 cm	80'000
TV Sat	10 GHz	3 cm	8000
Radar	100 GHz	3 mm	800
Infrared	10 THz	3 microns	8
Visible light	500 THz	600 nm	4
Ultraviolet UVA	1000 THz	300 nm	2
Ultraviolet UVB	10000 THz	30 nm	0.2
X Rays	Million THz	0.3 nm	0.0002
Gamma rays	more	less	less

Are electromagnetic waves dangerous ?

(2)
 Power density at a
MACROSCOPIC Level
 $P = E H =$
 electric field x magnetic
 field
 [mW/cm²]

In a microwave oven	500
Airport RADAR at 10 m	300
solar rays outside the atmosphere	140
Evident danger	>100
Systematic effects	>50
Sun during a nice ski day	10
FCC Public Exposure Standard	0.5
Good cell phone in the head	0.3
60 W bulb at 1 m	0.02
Good cell phone base station	5E-04
FM radio transmitter at 10 Km	1E-04
Sat. TV at street level	1E-06

Analogy **Electromagnetic waves** = Rain
Frequency = size of drops ; **Puissance** = density of drops

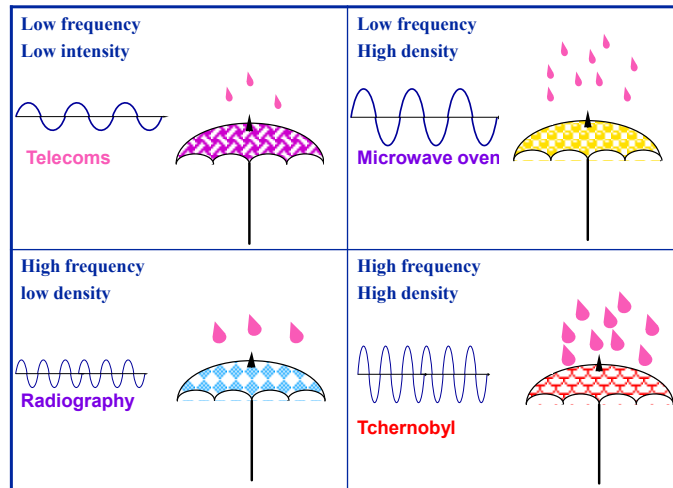

Non thermal biological effect

- Controversial since more than 30 years
 - Do they exist? (probably yes)
 - Are they harmful? (probably no)
- In doubt:
- Lower the limits